



A Donaldson Company

FUMECAB 1000 iQ FUME EXTRACTOR

LAST UPDATED ON 07.23.2024

A WORLD LEADER IN FUME
EXTRACTION TECHNOLOGY

The FumeCAB 1000 iQ integrated filtration system has been designed to help ensure compliance with the latest regulations.

Ultra-bright, slimline, energy saving LED lights and UV lighting come as standard, along with VOC monitoring.

The innovative cam filter change design helps enable safer and simple front loading filter replacement and provides many benefits over alternative rear access systems.



Intelligent
Operating
System (iQ)



HEPA
filter



Advanced
carbon
filter (ACF)
technology



Automatic flow
control (AFC)
technology



Reverse flow
air (RFA)
technology



SureCHECK
quality
standard



Patented
technology

Key features

- Certified to BS 7989:2001 recirculatory filtration fume cabinet specification
- Helps to ensure operational compliance with HSG258 guidelines
- Reverse flow filter technology
- Automatic flow control system
- Energy saving, ultra-bright, slimline LED lighting
- Twin coated anti-UV/anti-splash protective polycarbonate visor
- Combined HEPA/gas filter incorporating ACF technology
- Filters with long life and low replacement cost
- Real-time airflow reading, with independent filter condition monitoring, display and warnings
- Large working area
- Side entry blind grommets for equipment access
- VOC gas sensor (volatile organic compound)
- UV lighting
- Optional filter medias and stand

Technical specification

1. iQ display
2. On/off switch
3. Filter compartment hinges
4. Cable entry grommet
5. Transparent visor
6. Hinges
7. Mains inlet
8. LED lighting
9. Exhaust
10. Cooling air inlet
11. Standby button
12. UV lighting (optional)

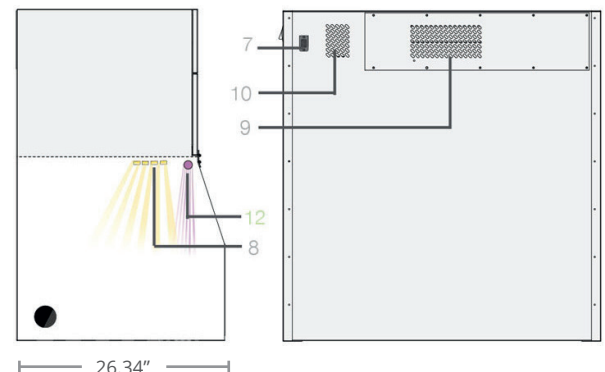
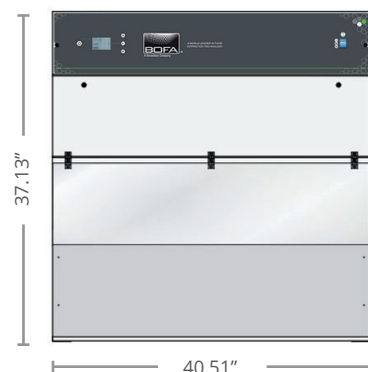

Airflow through filters

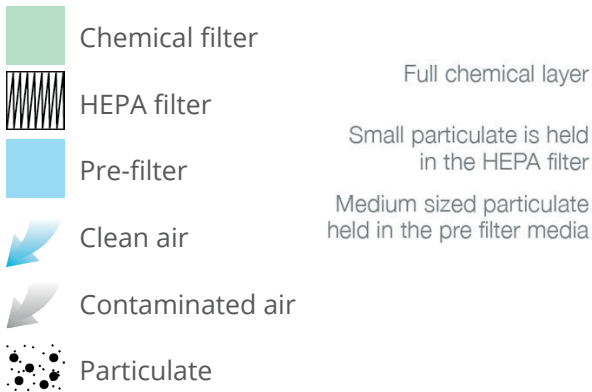

Internal working area

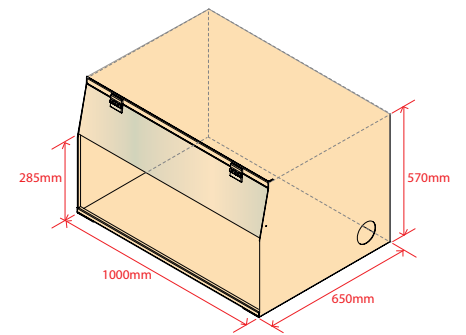

Technical data

Dimensions (HxWxD)	37.13 x 40.51 x 26.34"
Opening dimensions (HxWxD)	11.2 x 39.4 x 25.6"
Face velocity	78.7ft/min
Max face velocity	118ft/min
Cabinet construction	Powder-coated mild steel
Electrical data	115v 50/60Hz Full load current: 10 amps
Noise level	< 60 dBA (at typical operating speed)
Weight (standard extractor with filters)	264lbs (+/- 5%)
Exhaust outlet (optional)	125mm
Approvals	UKCA and CE

Contact BOFA at donaldsonbofa.com/contact/

Datasheet correct at time of publishing.

Where applicable, the carbon used in BOFA units is capable of removing a wide range of VOCs, however it is the responsibility of the user to ensure the carbon is suitable for their application. For specific applications, please contact us for details.

Important notice: Many factors beyond the control of BOFA can affect the use and performance of BOFA products in a particular application, including the conditions under which the product is used. Since these factors are uniquely within the user's knowledge and control, it is essential the user evaluate the products to determine whether the product is fit for the particular purpose and suitable for the user's application. All products, product specifications, availability and data are subject to change without notice, and may vary by region or country.

Think before you print! Please consider the environment before printing this document.

Pre-filter specifications

Filter media construction	Filter pad
Filter efficiency	99% @ 0.3 microns

Combined HEPA/gas filter specifications

HEPA filter media	Borosilicate
HEPA media construction	Maxi pleat construction with glue bead spacers
Gas filter	Treated activated carbon
Treated activated carbon	37.4 lbs
Filter efficiency	99.995% @ 0.3 microns

Part numbers

Model	FumeCAB 1000 iQ - Powder-coated
Includes UV lighting and VOC	As standard
Part number	1U41998510850560-1451
Replacement filters	
Pre-filter	1UA1030249
Combined HEPA/gas filter	1UA1030250



Approvals: REACH and RoHS.
See individual product technical data for specific accreditations.

